

SPC Method for Reducing Glass and Laminate Damage

Frame Press

1 Cut and position a sheet of Fujifilm Prescale® along the outside perimeter between the frame and the pneumatic push bar/backstop during module alignment and prior to applying edge sealant and corner keys.

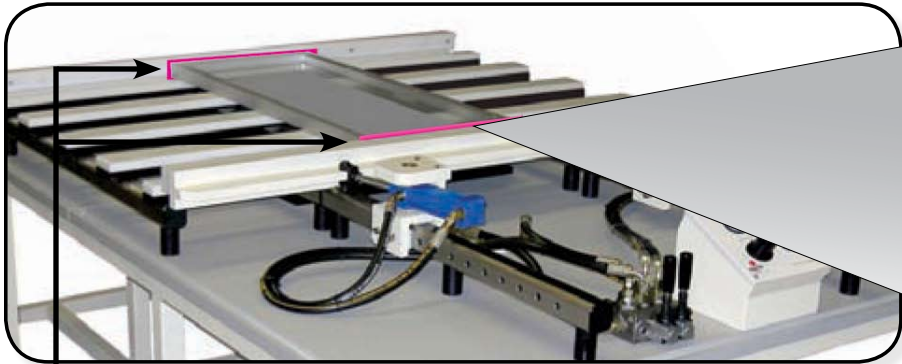

● Place Fujifilm Prescale® tactile surface sensors here

Zoomed View

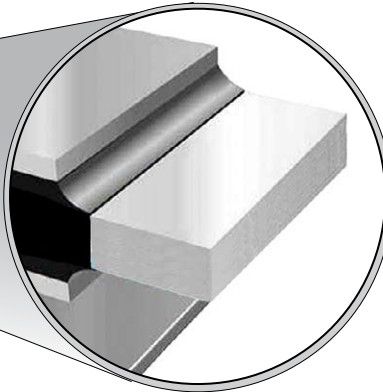

Zoomed View

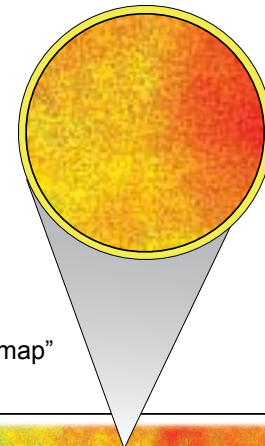

Pressure Profile

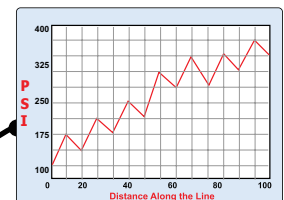

2 Instantaneously and permanently the film captures both the pressure distribution and magnitude that occurs between the contacting surfaces.

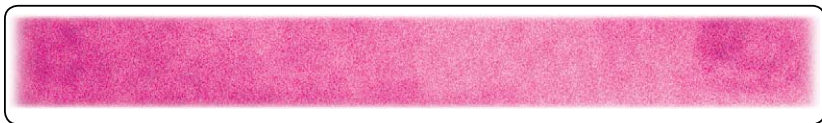

3 Final analysis: a "pressure map"

